

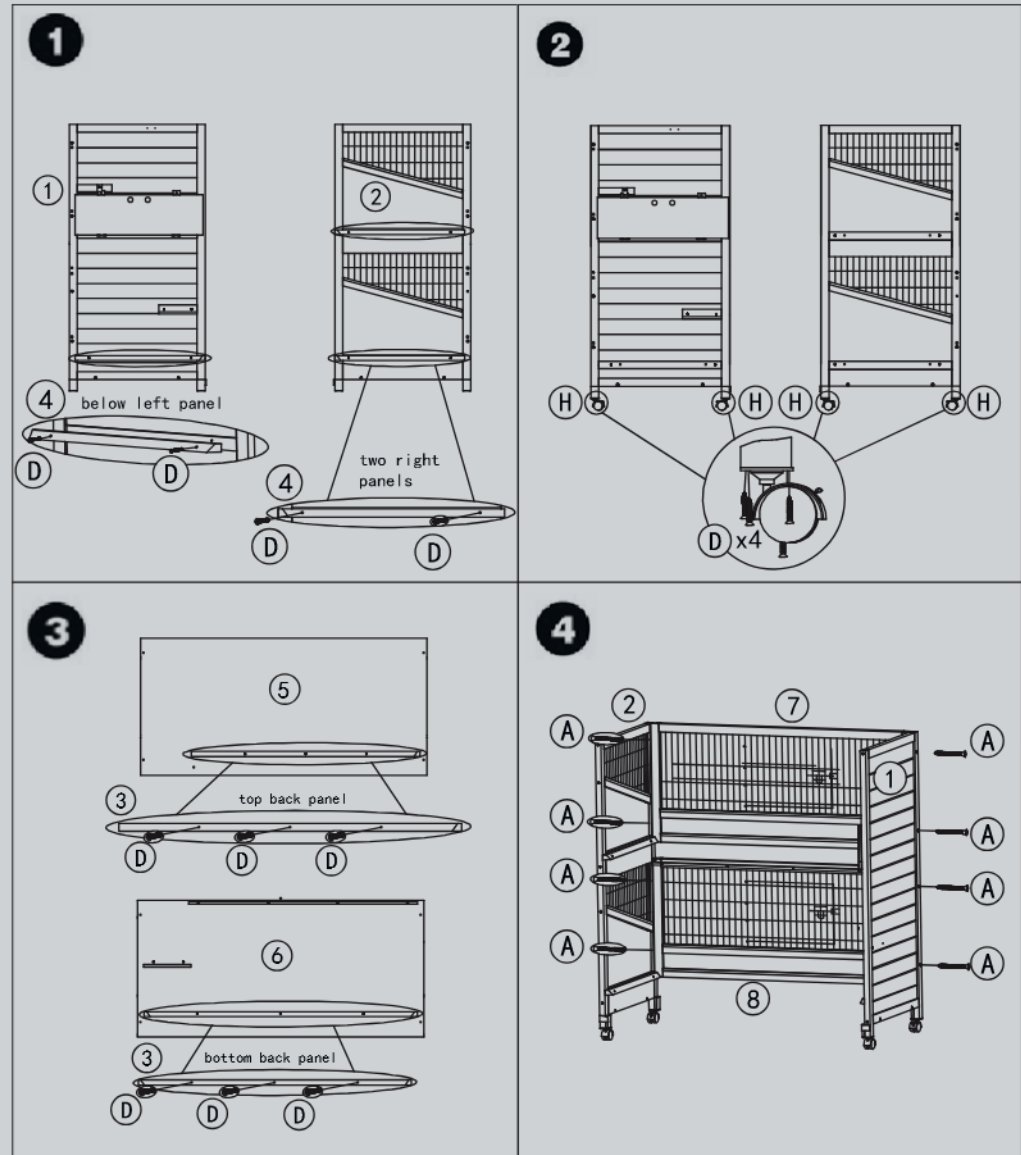

A M3.5X50 14pcs	B M3.5X35 9pcs	C M3.0X30 6pcs	D M3.0X25 29pcs
E M3.0X14 15pcs	F 1pcs	G 1pcs	H 4pcs
1 1pcs	2 1pcs	3 top back panel bottom back panel 2pcs	4 right panels below left panel 3pcs
5 1pcs	6 1pcs	7 1pcs	8 1pcs
9 1pcs	10 1pcs	11 1pcs	12 S L 2pcs
13 2pcs	14 1pcs		

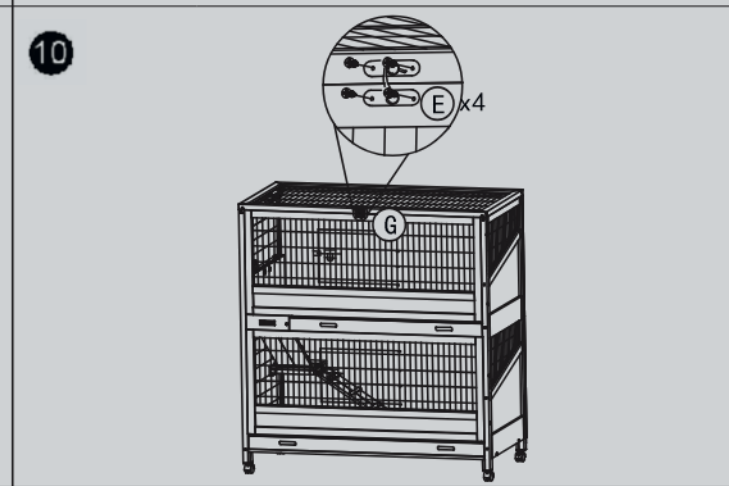

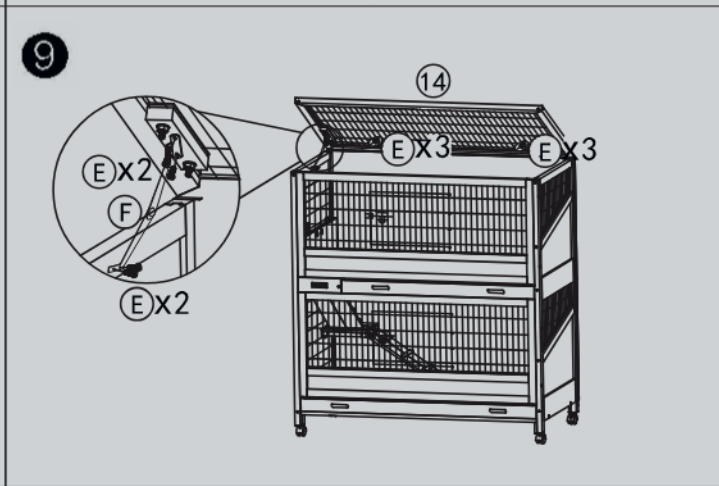
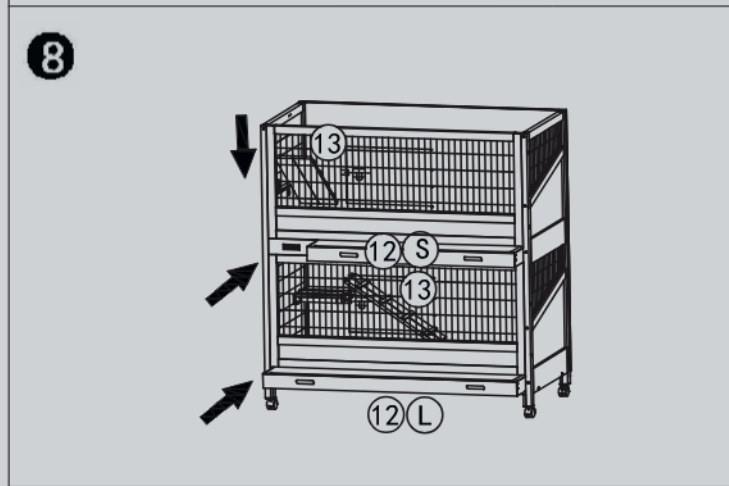
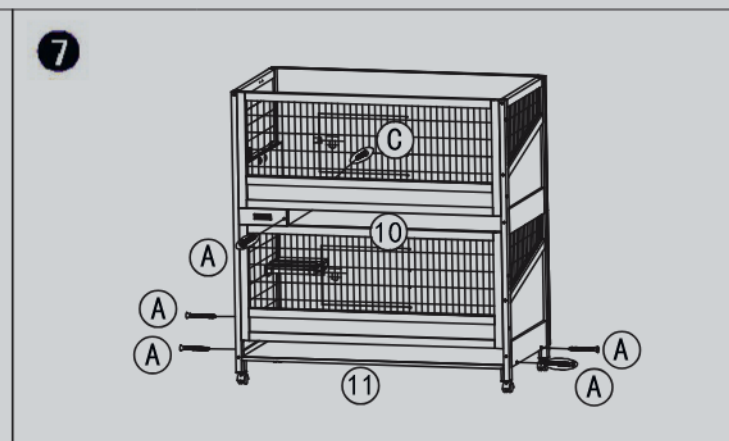
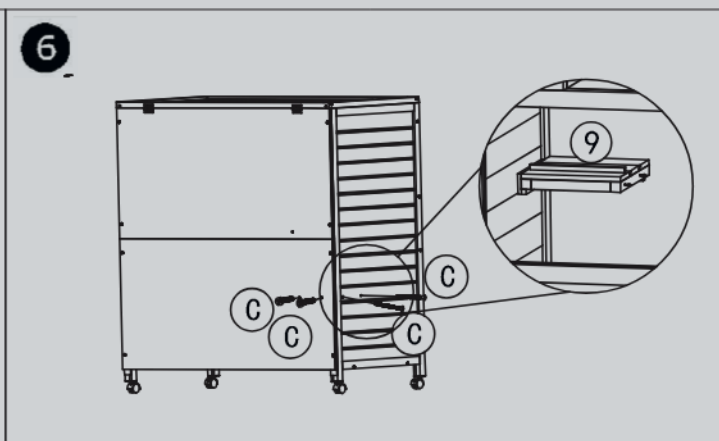
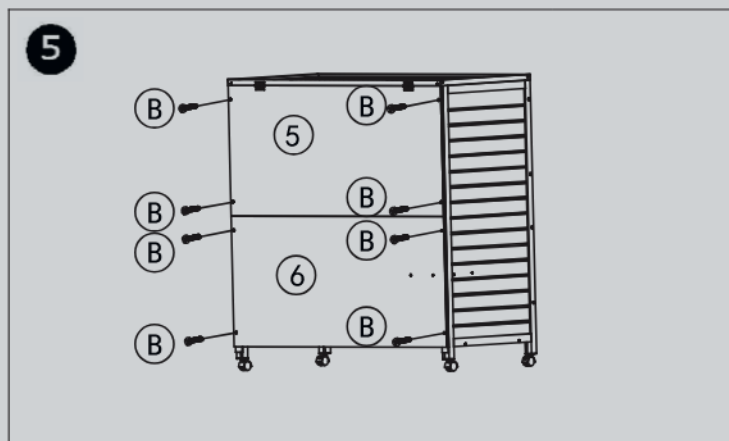

(DE) Bitte beachten Sie, dass eventuell durchlaufende Flüssigkeiten wie Wasser oder Urin den Fußboden beschädigen könnten. Der ideale Untergrund sind Stein-, Fliesen- oder Kunststoffböden.

(FR) Veuillez prendre en compte le fait que les fuites de liquides comme l'eau ou l'urine peuvent endommager le fond. Les sols en pierre, carrelage ou plastique constituent les meilleurs fonds.

(EN) Please take into account that any liquids that leak out such as water or urine may damage your floors. An ideal base would be stone, tile or synthetic floors.

(IT) Tenere presente che eventuali liquidi come acqua o urina possono danneggiare il pavimento. Il fondo ideale è composto da pietre, piastrelle o plastica.